

OPERATION MANUAL

MODELS 3672, 3673, 3675, 3676
1/4 DIN pH/ORP CONTROLLER

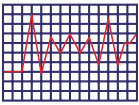

PULSE INSTRUMENTS

3233 Mission Oaks Blvd., Unit P - Camarillo, CA 93012 - (800) 462-1926 - support@pulseinstrument.com

OPERATION MANUAL

MODELS 3672, 3673, 3675, 3676
1/4 DIN pH/ORP CONTROLLER

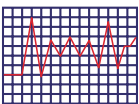

PULSE INSTRUMENTS

3233 Mission Oaks Blvd., Unit P - Camarillo, CA 93012 - (800) 462-1926 - support@pulseinstrument.com

INTENDED USE AND GENERAL INTRODUCTION

The models 3672, 3673, 3675 and 3676 are precise instruments for the measurement and control of pH and mV (ORP).

Two output relays are provided in the models 3675 and 3676 for ON/OFF control .

The isolated 4-20 mA output current of the models 3675 and 3676 corresponds to the input control range of 0 to 14 pH and 0 to 1400 mV.

A front panel programmable HIGH/LOW ALARM relay is provided in the models 3672 and 3673.

The isolated 4-20 mA output of the model 3672 can be set for a input control span of any 2 to 14 pH (200 to 1400 mV), via the front panel CONTROL SET POINT and SPAN ADJ controls. The output 4-20 mA current can be selected for increasing or decreasing values for increasing pH and mV (ORP) inputs. The isolated 4-20 mA output current of the model 3672 covers the input control range of 0 to 14.00 pH and ± 1999 mV.

The output pulse frequency of the model 3673 is proportional to the ion concentration, over a preset proportional band of 2 pH and 200 mV. The pulse frequency output can be selected for increasing or decreasing pulse rate for increasing pH and mV (ORP) inputs. The maximum pulse frequency can be adjusted by the front panel PULSE RATE ADJUST control. The pulse frequency output of the model 3673 covers the input control range of 0 to 14.00 pH and ± 1999 mV.

INTENDED USE AND GENERAL INTRODUCTION

The models 3672, 3673, 3675 and 3676 are precise instruments for the measurement and control of pH and mV (ORP).

Two output relays are provided in the models 3675 and 3676 for ON/OFF control .

The isolated 4-20 mA output current of the models 3675 and 3676 corresponds to the input control range of 0 to 14 pH and 0 to 1400 mV.

A front panel programmable HIGH/LOW ALARM relay is provided in the models 3672 and 3673.

The isolated 4-20 mA output of the model 3672 can be set for a input control span of any 2 to 14 pH (200 to 1400 mV), via the front panel CONTROL SET POINT and SPAN ADJ controls. The output 4-20 mA current can be selected for increasing or decreasing values for increasing pH and mV (ORP) inputs. The isolated 4-20 mA output current of the model 3672 covers the input control range of 0 to 14.00 pH and ± 1999 mV.

The output pulse frequency of the model 3673 is proportional to the ion concentration, over a preset proportional band of 2 pH and 200 mV. The pulse frequency output can be selected for increasing or decreasing pulse rate for increasing pH and mV (ORP) inputs. The maximum pulse frequency can be adjusted by the front panel PULSE RATE ADJUST control. The pulse frequency output of the model 3673 covers the input control range of 0 to 14.00 pH and ± 1999 mV.

A large LCD display is used for readability under bright ambient conditions.

The models 3672, 3673, 3675 and 3676 are housed in a rugged 1/4 DIN plastic case, allowing it to fit into standard panel cut-outs as well as the most commonly available industrial weatherproof and environmental housings.

INITIAL INSPECTION

Carefully unpack the instrument and accessories. Inspect for damage in shipment. If any damage is found, NOTIFY PULSE INSTRUMENTS IMMEDIATELY. All packing materials should be saved until satisfactory operation is confirmed.

A large LCD display is used for readability under bright ambient conditions.

The models 3672, 3673, 3675 and 3676 are housed in a rugged 1/4 DIN plastic case, allowing it to fit into standard panel cut-outs as well as the most commonly available industrial weatherproof and environmental housings.

INITIAL INSPECTION

Carefully unpack the instrument and accessories. Inspect for damage in shipment. If any damage is found, NOTIFY PULSE INSTRUMENTS IMMEDIATELY. All packing materials should be saved until satisfactory operation is confirmed.

FRONT PANEL FORMAT FOR THE MODEL 3672

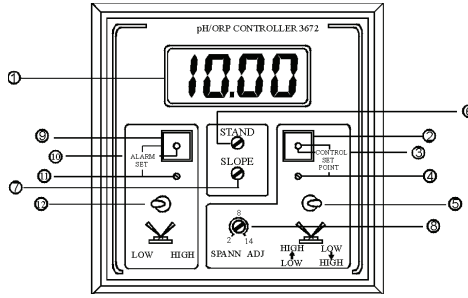

- | | |
|---------------------------------|---|
| 1. LCD display | 7. pH SLOPE control |
| 2. CONTROL SET POINT switch | 8. 4-20 mA SPAN ADJUST control |
| 3. CONTROL SET POINT LED | 9. ALARM SET POINT switch |
| 4. CONTROL SET POINT control | 10. ALARM SET POINT LED |
| 5. OUTPUT CURRENT SELECT switch | 11. ALARM SET POINT control |
| 6. pH STANDARDIZATION control | 12. ALARM SET POINT HIGH /LOW SELECT switch |

FIGURE 1A

FRONT PANEL FORMAT FOR THE MODEL 3672

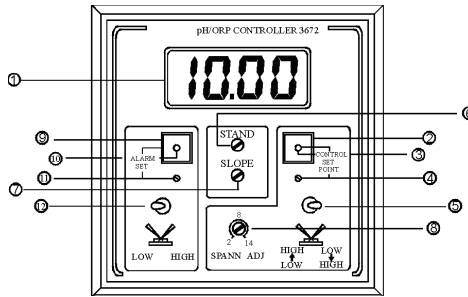

- | | |
|---------------------------------|---|
| 1. LCD display | 7. pH SLOPE control |
| 2. CONTROL SET POINT switch | 8. 4-20 mA SPAN ADJUST control |
| 3. CONTROL SET POINT LED | 9. ALARM SET POINT switch |
| 4. CONTROL SET POINT control | 10. ALARM SET POINT LED |
| 5. OUTPUT CURRENT SELECT switch | 11. ALARM SET POINT control |
| 6. pH STANDARDIZATION control | 12. ALARM SET POINT HIGH /LOW SELECT switch |

FIGURE 1A

REAR PANEL FORMAT FOR THE MODEL 3672

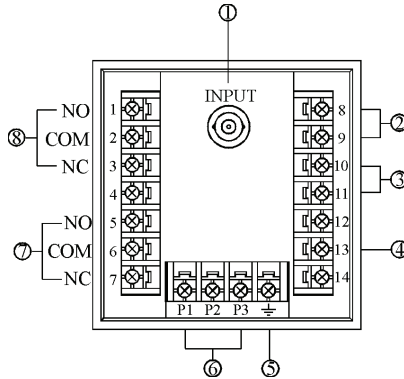

1. pH/mV electrode BNC input
2. ATC probe input
3. Isolated 4-20 mA output
4. Reference electrode input

5. EARTH ground
6. AC power input
7. ALARM output relay
8. CONTROL output relay

FIGURE 2A

4

REAR PANEL FORMAT FOR THE MODEL 3672

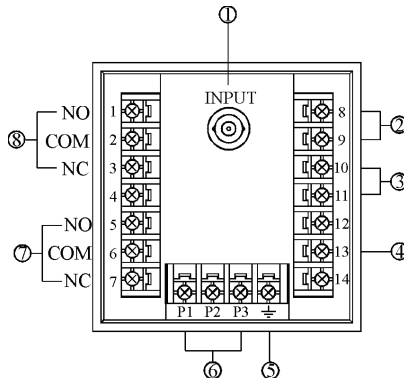

1. pH/mV electrode BNC input
2. ATC probe input
3. Isolated 4-20 mA output
4. Reference electrode input

5. EARTH ground
6. AC power input
7. ALARM output relay
8. CONTROL output relay

FIGURE 2A

4

FRONT PANEL FORMAT FOR THE MODEL 3673

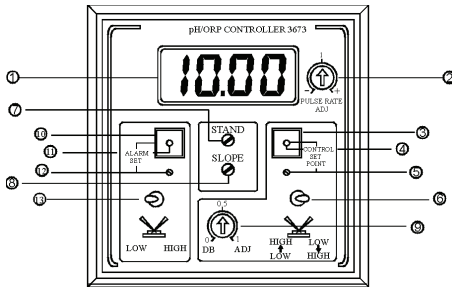

- | | |
|--|--|
| <ol style="list-style-type: none"> 1. LCD display 2. PULSE RATE ADJUST control 3. CONTROL SET POINT switch 4. CONTROL SET POINT LED 5. CONTROL SET POINT control 6. PULSE FREQUENCY HIGH/LOW SELECT switch | <ol style="list-style-type: none"> 7. pH STANDARDIZATION control 8. pH SLOPE control 9. DEAD AND ADJUST control 10. ALARM SET POINT switch 11. ALARM SET POINT LED 12. ALARM SET POINT control 13. ALARM SET POINT HIGH/LOW SELECT switch |
|--|--|

FIGURE 1B

FRONT PANEL FORMAT FOR THE MODEL 3673

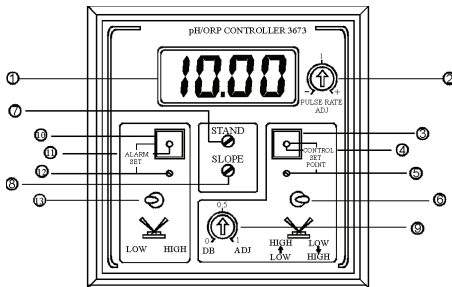

- | | |
|--|--|
| <ol style="list-style-type: none"> 1. LCD display 2. PULSE RATE ADJUST control 3. CONTROL SET POINT switch 4. CONTROL SET POINT LED 5. CONTROL SET POINT control 6. PULSE FREQUENCY HIGH/LOW SELECT switch | <ol style="list-style-type: none"> 7. pH STANDARDIZATION control 8. pH SLOPE control 9. DEAD AND ADJUST control 10. ALARM SET POINT switch 11. ALARM SET POINT LED 12. ALARM SET POINT control 13. ALARM SET POINT HIGH/LOW SELECT switch |
|--|--|

FIGURE 1B

REAR PANEL FORMAT FOR THE MODEL 3673

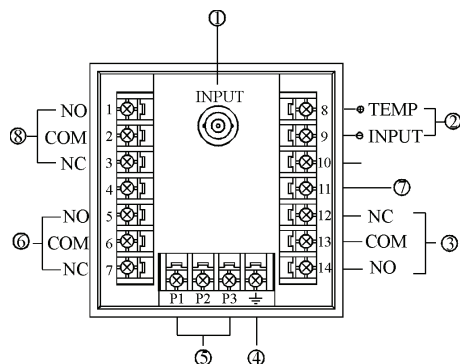

- | | |
|--|---|
| <ul style="list-style-type: none"> 1. pH/mV electrode BNC input 2. ATC probe input 3. Pulse frequency output 4. EARTH ground | <ul style="list-style-type: none"> 5. AC power input 6. ALARM output relay 7. Reference electrode input 8. CONTROL output relay |
|--|---|

FIGURE 2B

6

REAR PANEL FORMAT FOR THE MODEL 3673

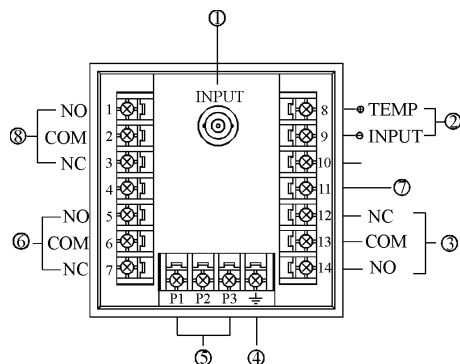

- | | |
|--|---|
| <ul style="list-style-type: none"> 1. pH/mV electrode BNC input 2. ATC probe input 3. Pulse frequency output 4. EARTH ground | <ul style="list-style-type: none"> 5. AC power input 6. ALARM output relay 7. Reference electrode input 8. CONTROL output relay |
|--|---|

FIGURE 2B

6

FRONT PANEL FORMAT FOR THE MODEL 3675

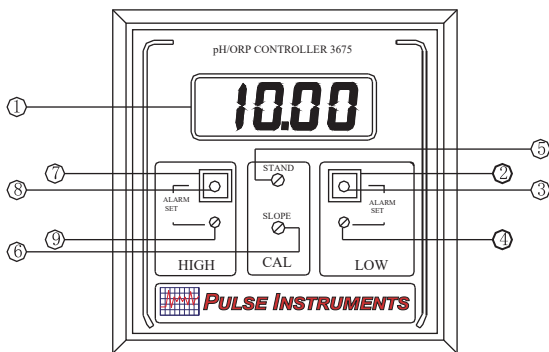

- | | |
|--------------------------------|---------------------------------|
| 1. LCD display | 6. pH SLOPE control |
| 2. LOW ALARM SET POINT switch | 7. HIGH ALARM SET POINT switch |
| 3. LOW ALARM SET POINT LED | 8. HIGH ALARM SET POINT LED |
| 4. LOW ALARM SET POINT control | 9. HIGH ALARM SET POINT control |
| 5. pH STANDARDIZATION control | |

FIGURE 1 C

7

FRONT PANEL FORMAT FOR THE MODEL 3675

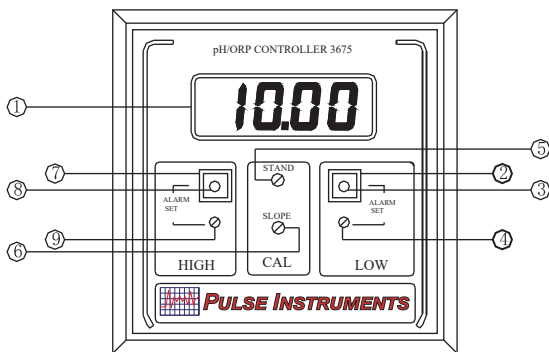

- | | |
|--------------------------------|---------------------------------|
| 1. LCD display | 6. pH SLOPE control |
| 2. LOW ALARM SET POINT switch | 7. HIGH ALARM SET POINT switch |
| 3. LOW ALARM SET POINT LED | 8. HIGH ALARM SET POINT LED |
| 4. LOW ALARM SET POINT control | 9. HIGH ALARM SET POINT control |
| 5. pH STANDARDIZATION control | |

FIGURE 1 C

7

REAR PANEL FORMAT FOR THE MODEL 3675

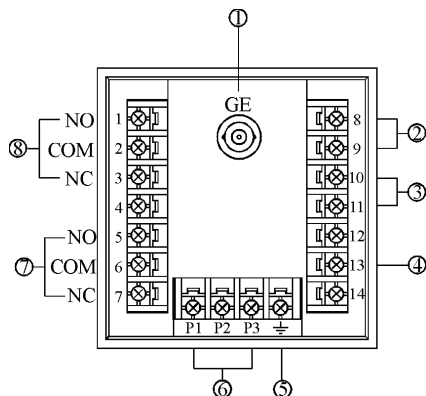

- | | |
|-------------------------------|----------------------------|
| 1. pH/mV. electrode BNC input | 5. EARTH ground |
| 2. ATC probe input | 6. AC power input |
| 3. Isolated 4-20 mA output | 7. HIGH ALARM output relay |
| 4. Reference electrode input | 8. LOW ALARM output relay |

FIGURE 2C

8

REAR PANEL FORMAT FOR THE MODEL 3675

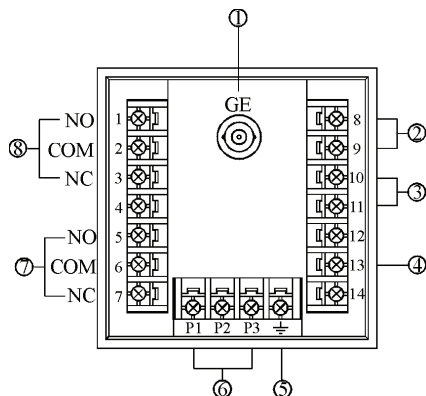

- | | |
|-------------------------------|----------------------------|
| 1. pH/mV. electrode BNC input | 5. EARTH ground |
| 2. ATC probe input | 6. AC power input |
| 3. Isolated 4-20 mA output | 7. HIGH ALARM output relay |
| 4. Reference electrode input | 8. LOW ALARM output relay |

FIGURE 2C

8

FRONT PANEL FORMAT FOR THE MODEL 3676

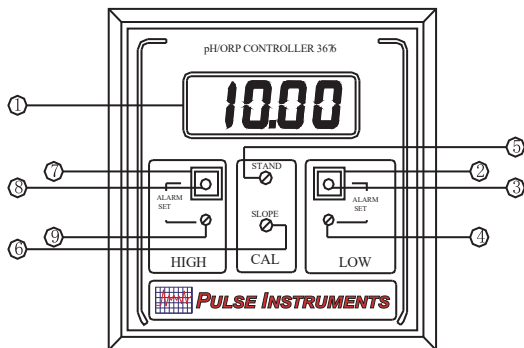

- | | |
|--------------------------------|---------------------------------|
| 1. LCD display | 6. pH SLOPE control |
| 2. LOW ALARM SET POINT switch | 7. HIGH ALARM SET POINT switch |
| 3. LOW ALARM SET POINT LED | 8. HIGH ALARM SET POINT LED |
| 4. LOW ALARM SET POINT control | 9. HIGH ALARM SET POINT control |
| 5. pH STANDARDIZATION control | |

FIGURE 1D

9

FRONT PANEL FORMAT FOR THE MODEL 3676

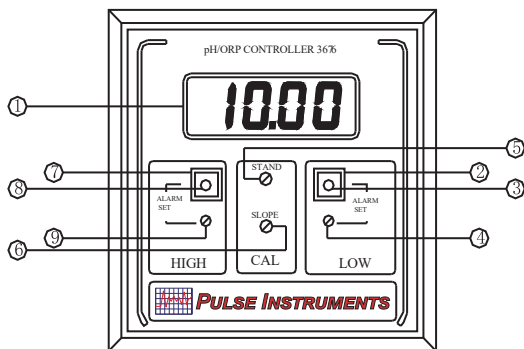

- | | |
|--------------------------------|---------------------------------|
| 1. LCD display | 6. pH SLOPE control |
| 2. LOW ALARM SET POINT switch | 7. HIGH ALARM SET POINT switch |
| 3. LOW ALARM SET POINT LED | 8. HIGH ALARM SET POINT LED |
| 4. LOW ALARM SET POINT control | 9. HIGH ALARM SET POINT control |
| 5. pH STANDARDIZATION control | |

FIGURE 1D

9

REAR PANEL FORMAT FOR THE MODEL 3676

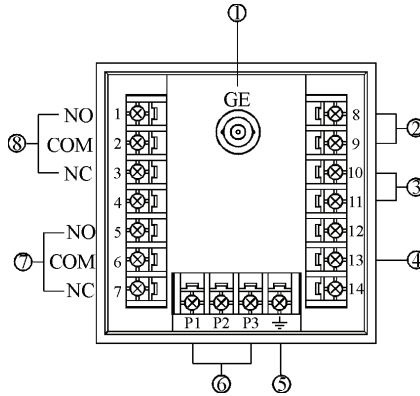

- | | |
|-------------------------------|----------------------------|
| 1. pH/mV. electrode BNC input | 5. EARTH ground |
| 2. ATC probe input | 6. AC power input |
| 3. Isolated 4-20 mA output | 7. HIGH ALARM output relay |
| 4. Reference electrode input | 8. LOW ALARM output relay |

FIGURE 2D

REAR PANEL FORMAT FOR THE MODEL 3676

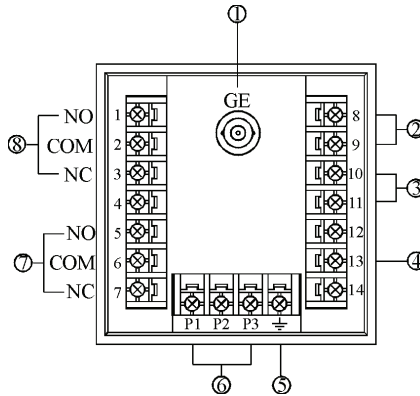

- | | |
|-------------------------------|----------------------------|
| 1. pH/mV. electrode BNC input | 5. EARTH ground |
| 2. ATC probe input | 6. AC power input |
| 3. Isolated 4-20 mA output | 7. HIGH ALARM output relay |
| 4. Reference electrode input | 8. LOW ALARM output relay |

FIGURE 2D

SIDE VIEW

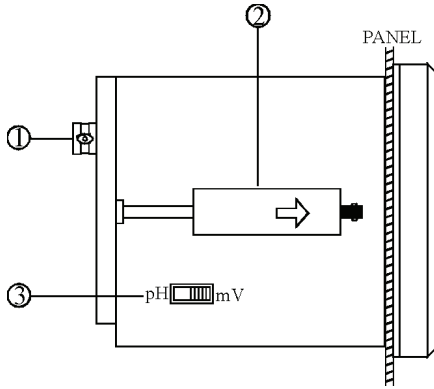

- 1. pH/mV input BNC connector
- 2. Mounting bracket

- 3. pH/mV SELECT switch

FIGURE 3

SIDE VIEW

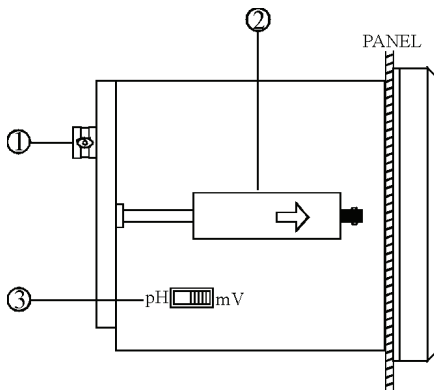

- 1. pH/mV input BNC connector
- 2. Mounting bracket

- 3. pH/mV SELECT switch

FIGURE 3

TEMPERATURE COMPENSATION

The models 3672, 3673, 3675 and 3676 are designed to be used with a PT-100 RTD temperature probe for automatic temperature compensation, ATC, operations. The alpha value of the PT-100 element is 0.00385.

A precision 0.1% resistor can be connected across the ATC input terminals to simulate a fixed process temperature.

TEMPERATURE COMPENSATION

The models 3672, 3673, 3675 and 3676 are designed to be used with a PT-100 RTD temperature probe for automatic temperature compensation, ATC, operations. The alpha value of the PT-100 element is 0.00385.

A precision 0.1% resistor can be connected across the ATC input terminals to simulate a fixed process temperature.

Temperature in °C	Resistor value in Ohms
0	100.00
10	103.90
20	107.79
25	109.73
30	111.67
40	115.54
50	119.40
60	123.24
70	127.07
80	130.89
90	134.78
100	138.50

TABLE 1

13

Temperature in °C	Resistor value in Ohms
0	100.00
10	103.90
20	107.79
25	109.73
30	111.67
40	115.54
50	119.40
60	123.24
70	127.07
80	130.89
90	134.78
100	138.50

TABLE 1

13

REAR PANEL CONNECTION SCHEME

(Refer to FIGURE 1A/1B/1C/1D and FIGURE 2A/2B/2C/2D)

1. Connect the AC line to the rear terminals of the instrument. The instrument can be powered by 115 VAC or 230 VAC, 50/60 Hz. Make sure that the Earth terminal is connected to the earth lead of the AC power line.
2. Connect the proper load to the output relays. Be sure that the load does not exceed the relay rating, 5 Amp at 115 VAC and 2.5 Amp at 230 VAC for RESISTIVE load only.
3. Set the pH/mV switch to the position for pH or mV operations. (Refer to FIGURE 3)
4. Load connections
Models 3672/3675/3676
Connect the proper load to the 4-20 mA output terminals. Make common mode voltage does not exceed 500 VDC.
Model 3673
Connect the pulse pump input leads to the output terminals of the pulse frequency output. The common mode voltage is not to exceed 1500 VDC.
5. Increasing/decreasing outputs for increasing pH (mV) inputs
Model 3672 Refer to pages 10, 11, 12.
Set the OUTPUT CURRENT SELECT switch to the desired position.
Model 3673 Refer to pages 10, 11, 12, 13.
Set the PULSE FREQUENCY SELECT switch to the desired position.
6. Electrode connections

REAR PANEL CONNECTION SCHEME

(Refer to FIGURE 1A/1B/1C/1D and FIGURE 2A/2B/2C/2D)

1. Connect the AC line to the rear terminals of the instrument. The instrument can be powered by 115 VAC or 230 VAC, 50/60 Hz. Make sure that the Earth terminal is connected to the earth lead of the AC power line.
2. Connect the proper load to the output relays. Be sure that the load does not exceed the relay rating, 5 Amp at 115 VAC and 2.5 Amp at 230 VAC for RESISTIVE load only.
3. Set the pH/mV switch to the position for pH or mV operations. (Refer to FIGURE 3)
4. Load connections
Models 3672/3675/3676
Connect the proper load to the 4-20 mA output terminals. Make common mode voltage does not exceed 500 VDC.
Model 3673
Connect the pulse pump input leads to the output terminals of the pulse frequency output. The common mode voltage is not to exceed 1500 VDC.
5. Increasing/decreasing outputs for increasing pH (mV) inputs
Model 3672 Refer to pages 10, 11, 12.
Set the OUTPUT CURRENT SELECT switch to the desired position.
Model 3673 Refer to pages 10, 11, 12, 13.
Set the PULSE FREQUENCY SELECT switch to the desired position.
6. Electrode connections

- 6.1 Combination pH (mV) electrodes
Connect the pH (mV) electrode cable to the pH/mV electrode BNC input connector.
- 6.2 Separate pH (mV) electrodes
Connect the working electrode to the pH/mV electrode BNC input connector.
Connect the reference electrode to the Reference input terminal.
- 7. Temperature compensation input connections
 - 7.1 ATC mode
Connect the automatic temperature compensation, ATC, probe to the ATC input terminals.
 - 7.2 A precision 0.1% resistor can be connected across the ATC terminals to simulate a fixed process temperature. (Refer to TABLE 1)

MOUNTING PROCEDURE

- 1. Make a cutout on any panel, with a thickness of 1/16 in. (1.5 mm) to 3/8 in. (9.5 mm). (Refer to FIGURE 4)
- 2. Remove the mounting brackets assembly from the panel meter and insert the panel meter into the cutout. (Refer to Figure 5)
- 3. Replace the mounting brackets assembly onto the panel meter and fasten the mounting screws to secure the panel meter to the mounting panel. (Refer to Figure 6)

15

- 6.1 Combination pH (mV) electrodes
Connect the pH (mV) electrode cable to the pH/mV electrode BNC input connector.
- 6.2 Separate pH (mV) electrodes
Connect the working electrode to the pH/mV electrode BNC input connector.
Connect the reference electrode to the Reference input terminal.
- 7. Temperature compensation input connections
 - 7.1 ATC mode
Connect the automatic temperature compensation, ATC, probe to the ATC input terminals.
 - 7.2 A precision 0.1% resistor can be connected across the ATC terminals to simulate a fixed process temperature. (Refer to TABLE 1)

MOUNTING PROCEDURE

- 1. Make a cutout on any panel, with a thickness of 1/16 in. (1.5 mm) to 3/8 in. (9.5 mm). (Refer to FIGURE 4)
- 2. Remove the mounting brackets assembly from the panel meter and insert the panel meter into the cutout. (Refer to Figure 5)
- 3. Replace the mounting brackets assembly onto the panel meter and fasten the mounting screws to secure the panel meter to the mounting panel. (Refer to Figure 6)

15

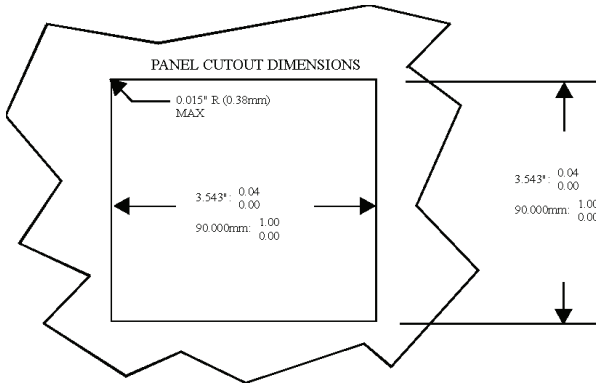

Panel Cutout
FIGURE 4

16

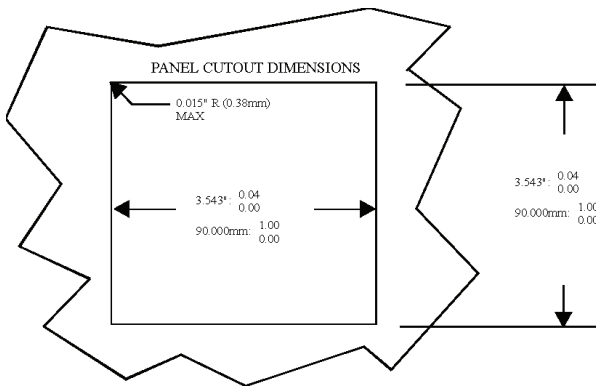

Panel Cutout
FIGURE 4

16

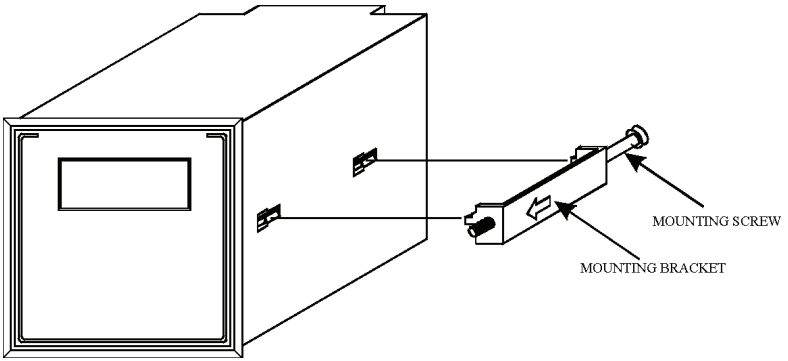

Panel Meter With Mounting Bracket And Screw

FIGURE 5

17

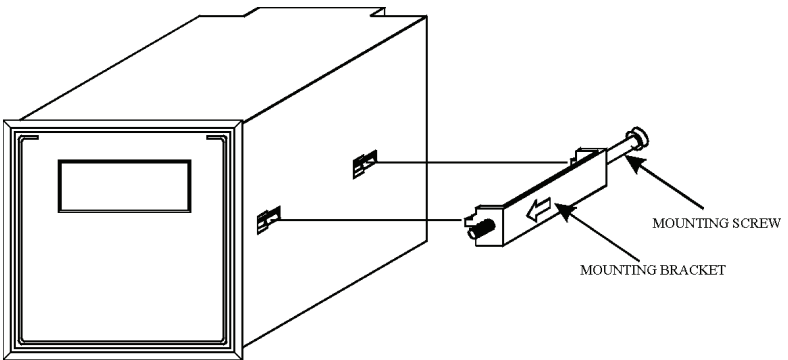

Panel Meter With Mounting Bracket And Screw

FIGURE 5

17

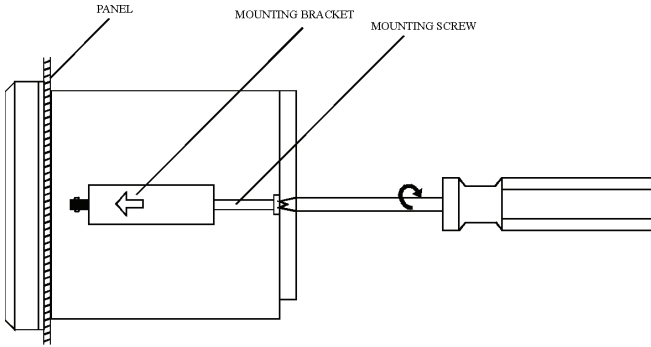

DRAWING 3 MOUNTING METHOD

Mounting Method FIGURE 6

18

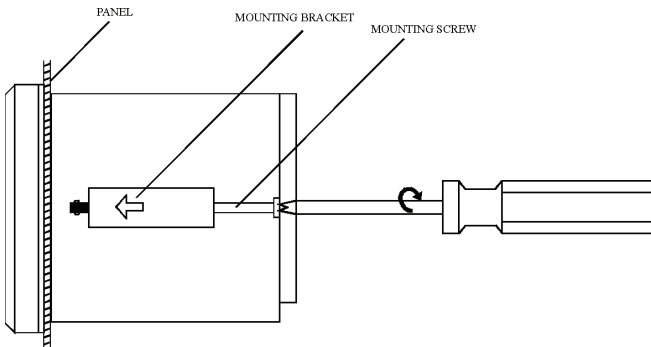

DRAWING 3 MOUNTING METHOD

Mounting Method FIGURE 6

18

pH CALIBRATION

Refer to REAR PANEL CONNECTION SCHEME.

Refer to TEMPERATURE COMPENSATION.

1. Rinse the pH electrode and ATC probe with distilled water.
2. Measure the temperature of the buffer 7 solution with a precision thermometer.
3. Immerse the pH electrode and ATC/TEMP probe in buffer 7. Allow sufficient time for the pH electrode and ATC probe to reach temperature equilibrium with the buffer 7.
4. Adjust the STAND control for the instrument to display the buffer value corresponding to the temperature measured in 2. Refer to TABLE 2.
5. Remove the pH electrode and ATC probe from buffer 7 and rinse with distilled water.
6. Measure the temperature of a second buffer with a precision thermometer.
7. Immerse the pH electrode and ATC probe in the second buffer .For accurate pH measurements, the second buffer should be close in pH and temperature values to process under test. In practice, pH buffers 4 and 10 are commonly used.
8. Adjust the SLOPE control for the instrument to display the buffer value corresponding to the temperature measured in 6. Refer to TABLE 2.
9. Remove the pH electrode and ATC probe from the second buffer and rinse with distilled water. The instrument is dual point calibrated and ready for measurements.

pH CALIBRATION

Refer to REAR PANEL CONNECTION SCHEME.

Refer to TEMPERATURE COMPENSATION.

1. Rinse the pH electrode and ATC probe with distilled water.
2. Measure the temperature of the buffer 7 solution with a precision thermometer.
3. Immerse the pH electrode and ATC/TEMP probe in buffer 7. Allow sufficient time for the pH electrode and ATC probe to reach temperature equilibrium with the buffer 7.
4. Adjust the STAND control for the instrument to display the buffer value corresponding to the temperature measured in 2. Refer to TABLE 2.
5. Remove the pH electrode and ATC probe from buffer 7 and rinse with distilled water.
6. Measure the temperature of a second buffer with a precision thermometer.
7. Immerse the pH electrode and ATC probe in the second buffer .For accurate pH measurements, the second buffer should be close in pH and temperature values to process under test. In practice, pH buffers 4 and 10 are commonly used.
8. Adjust the SLOPE control for the instrument to display the buffer value corresponding to the temperature measured in 6. Refer to TABLE 2.
9. Remove the pH electrode and ATC probe from the second buffer and rinse with distilled water. The instrument is dual point calibrated and ready for measurements.

TEMPERATURE COEFFICIENT OF THE pH BUFFERS
BUFFERS

°C	10.01	7.00	4.01
0	10.32	7.11	4.00
5	10.25	7.08	4.00
10	10.18	7.06	4.00
15	10.12	7.03	4.00
20	10.06	7.01	4.00
25	10.01	7.00	4.01
30	9.97	6.98	4.02
35	9.93	6.98	4.02
40	9.89	6.97	4.03
45	9.86	6.97	4.04
50	9.83	6.97	4.06
55	9.80	6.97	4.07
60	9.78	6.98	4.10

TABLE 2

20

TEMPERATURE COEFFICIENT OF THE pH BUFFERS
BUFFERS

°C	10.01	7.00	4.01
0	10.32	7.11	4.00
5	10.25	7.08	4.00
10	10.18	7.06	4.00
15	10.12	7.03	4.00
20	10.06	7.01	4.00
25	10.01	7.00	4.01
30	9.97	6.98	4.02
35	9.93	6.98	4.02
40	9.89	6.97	4.03
45	9.86	6.97	4.04
50	9.83	6.97	4.06
55	9.80	6.97	4.07
60	9.78	6.98	4.10

TABLE 2

20

ISOLATION VOLTAGE

The differential voltage between the outputs and the load should not exceed the maximum values. Exceeding the maximum values may cause permanent damage to the instrument and load.

1. Relay output

The maximum isolation voltage of the relay output contacts is 1500 VDC. The voltage differential between the relay output contacts and the load should not exceed 1500 VDC.

2. Current output

The maximum isolation voltage of the 4-20 mA output is 500 VDC. The voltage differential between the 4-20 mA output and the load should not exceed 500 VDC.

OUTPUT LOAD

1. Relay output

The current through the relay output contacts should not exceed 5 Amp at 115 VAC and 2.5 Amp at 230 VAC in order to cause permanent damage the relay contacts. This rating is specified for RESISTIVE loads only.

2. Current output

The maximum load is 550 ohms. Output current inaccuracies may occur for load impedance in excess of 550 ohms.

ISOLATION VOLTAGE

The differential voltage between the outputs and the load should not exceed the maximum values. Exceeding the maximum values may cause permanent damage to the instrument and load.

1. Relay output

The maximum isolation voltage of the relay output contacts is 1500 VDC. The voltage differential between the relay output contacts and the load should not exceed 1500 VDC.

2. Current output

The maximum isolation voltage of the 4-20 mA output is 500 VDC. The voltage differential between the 4-20 mA output and the load should not exceed 500 VDC.

OUTPUT LOAD

1. Relay output

The current through the relay output contacts should not exceed 5 Amp at 115 VAC and 2.5 Amp at 230 VAC in order to cause permanent damage the relay contacts. This rating is specified for RESISTIVE loads only.

2. Current output

The maximum load is 550 ohms. Output current inaccuracies may occur for load impedance in excess of 550 ohms.

CONTROLLER OUTPUT FEATURES OF THE MODEL 3672

The output of the model 3672 consists of two relays and an isolated 4-20 mA output. The isolated 4-20 mA output can be adjusted to cover input spans of 2-14 pH and 200 to 1400 mV. The operation of the 3672 is described below. (Refer to FIGURE 1A, FIGURE 2A.)

CONTROLLER INPUT RANGE

pH	0 to 14.00 pH
mV	±1999 mV

ALARM RELAY AND LED FORMATS

1. ALARM set point
 - 1.1 Press the ALARM SET POINT switch. The instrument will indicate the alarm set point value. The alarm set point value can be adjusted by the ALARM SET POINT control.
 - 1.2 Release the ALARM SET POINT switch. The instrument will indicate the measured process value.
2. ALARM SET POINT HIGH/LOW SELECT switch
 - 2.1 Set the ALARM SET POINT HIGH/LOW SELECT switch to the HIGH position. The ALARM SET POINT LED will be ON and the ALARM output relay will be

22

CONTROLLER OUTPUT FEATURES OF THE MODEL 3672

The output of the model 3672 consists of two relays and an isolated 4-20 mA output. The isolated 4-20 mA output can be adjusted to cover input spans of 2-14 pH and 200 to 1400 mV. The operation of the 3672 is described below. (Refer to FIGURE 1A, FIGURE 2A.)

CONTROLLER INPUT RANGE

pH	0 to 14.00 pH
mV	±1999 mV

ALARM RELAY AND LED FORMATS

1. ALARM set point
 - 1.1 Press the ALARM SET POINT switch. The instrument will indicate the alarm set point value. The alarm set point value can be adjusted by the ALARM SET POINT control.
 - 1.2 Release the ALARM SET POINT switch. The instrument will indicate the measured process value.
2. ALARM SET POINT HIGH/LOW SELECT switch
 - 2.1 Set the ALARM SET POINT HIGH/LOW SELECT switch to the HIGH position. The ALARM SET POINT LED will be ON and the ALARM output relay will be

22

energized when the measured value is greater than the alarm set point value. The ALARM SET POINT LED will be OFF and the ALARM output relay will be de-energized when the measured value is less than the alarm set point value.

2.2 Set the ALARM SET POINT HIGH/LOW SELECT switch to the LOW position. The ALARM SET POINT LED will be ON and the ALARM output relay will be energized when the measured value is less than the alarm set point value. The ALARM SET POINT LED will be OFF and the ALARM output relay will be de-energized when the measured value is greater than the alarm set point value.

3. Set point hysteresis

The hysteresis of the model 3672 is factory set to ± 0.1 pH (± 10 mV). For HIGH ALARM settings, the trigger ON point is 0.1 pH (10 mV) above the set point values and the trigger OFF point is 0.1 pH (10 mV) below the set point values. For LOW ALARM settings, the trigger ON point is 0.1 pH (10 mV) below the set point values and the trigger OFF point is 0.1 pH (10 mV) above the set point values.

ISOLATED 4-20 mA OUTPUT

1. CONTROL set point

1.1 Press the CONTROL SET POINT switch. The instrument will indicate the set point value. The control set point value can be adjusted by the CONTROL SET POINT control.

1.2 Release the CONTROL SET POINT switch. The instrument will indicate the

energized when the measured value is greater than the alarm set point value. The ALARM SET POINT LED will be OFF and the ALARM output relay will be de-energized when the measured value is less than the alarm set point value.

2.2 Set the ALARM SET POINT HIGH/LOW SELECT switch to the LOW position. The ALARM SET POINT LED will be ON and the ALARM output relay will be energized when the measured value is less than the alarm set point value. The ALARM SET POINT LED will be OFF and the ALARM output relay will be de-energized when the measured value is greater than the alarm set point value.

3. Set point hysteresis

The hysteresis of the model 3672 is factory set to ± 0.1 pH (± 10 mV). For HIGH ALARM settings, the trigger ON point is 0.1 pH (10 mV) above the set point values and the trigger OFF point is 0.1 pH (10 mV) below the set point values. For LOW ALARM settings, the trigger ON point is 0.1 pH (10 mV) below the set point values and the trigger OFF point is 0.1 pH (10 mV) above the set point values.

ISOLATED 4-20 mA OUTPUT

1. CONTROL set point

1.1 Press the CONTROL SET POINT switch. The instrument will indicate the set point value. The control set point value can be adjusted by the CONTROL SET POINT control.

1.2 Release the CONTROL SET POINT switch. The instrument will indicate the

measured process value.

2. OUTPUT CURRENT SELECT switch (Refer to FIGURE 7A)

- 2.1 Set the OUTPUT CURRENT SELECT switch to the [LOW-HIGH] position.
 - 2.1.1 The CONTROL SET POINT LED will be ON and the CONTROL output relay will be energized when the measured value is greater than the set point value. The CONTROL SET POINT LED will be OFF and the CONTROL output relay will be de-energized when the measured value is less than the set point value.
 - 2.1.2 The isolated current output is 4 mA at the CONTROL SET POINT value. The 20 mA output value is set by the SPAN ADJ control. The current output will increase for increasing input pH (mV) values.
- 2.2 Set the OUTPUT CURRENT SELECT SWITCH to the [HIGH-LOW] position.
 - 2.2.1 The CONTROL SET POINT LED will be ON and the CONTROL output relay will be energized when the measured value is less than the set point value. The CONTROL SET POINT LED will be OFF and the CONTROL output relay will be de-energized when the measured value is greater than the set point value.
 - 2.2.2 The isolated current output is 4 mA at the CONTROL SET POINT value. The 20 mA output value is set by the SPAN ADJ control. The current output will decrease for increasing input pH (mV) values.

3. SPAN ADJ control

24

measured process value.

2. OUTPUT CURRENT SELECT switch (Refer to FIGURE 7A)

- 2.1 Set the OUTPUT CURRENT SELECT switch to the [LOW-HIGH] position.
 - 2.1.1 The CONTROL SET POINT LED will be ON and the CONTROL output relay will be energized when the measured value is greater than the set point value. The CONTROL SET POINT LED will be OFF and the CONTROL output relay will be de-energized when the measured value is less than the set point value.
 - 2.1.2 The isolated current output is 4 mA at the CONTROL SET POINT value. The 20 mA output value is set by the SPAN ADJ control. The current output will increase for increasing input pH (mV) values.
- 2.2 Set the OUTPUT CURRENT SELECT SWITCH to the [HIGH-LOW] position.
 - 2.2.1 The CONTROL SET POINT LED will be ON and the CONTROL output relay will be energized when the measured value is less than the set point value. The CONTROL SET POINT LED will be OFF and the CONTROL output relay will be de-energized when the measured value is greater than the set point value.
 - 2.2.2 The isolated current output is 4 mA at the CONTROL SET POINT value. The 20 mA output value is set by the SPAN ADJ control. The current output will decrease for increasing input pH (mV) values.

3. SPAN ADJ control

24

The SPAN ADJ control is used to set the input span corresponding to the 4-20 mA output.

3.1 Input a stable pH (mV) voltage source for the display to indicate the value corresponding to the 4 mA output.

3.2 Set the CONTROL SET POINT control for the current output to be 4 mA.

3.3 Set the OUTPUT CURRENT SELECT switch to the proper position. [LOW-HIGH] for the 20 mA input value to be greater than the 4 mA input value and [HIGH-LOW] for the 20 mA input value to be less than the 4 mA input value.

3.4 Input a stable pH (mV) voltage source for the display to indicate the value corresponding to the 20 mA output. The 20 mA input value must be at least 2 pH (200 mV) away from the 4 mA input value.

3.5 Set the SPAN ADJ control for the current output to be 20 mA.

4. pH mode output

The pH value can be obtained by measuring the output current, “A” based on the following equation. Refer to FIGURE 7A.

$$\text{pH} = \text{pH} (4) + (A-4) \times ((\text{pH} (20) - \text{pH} (4)) / 16)$$

Where: pH (4) is the pH value at 4 mA output

pH (20) is the pH value at 20 mA output

Example: pH (4) = 3, pH (20) = 5

pH = 4 for A = 12 mA

The SPAN ADJ control is used to set the input span corresponding to the 4-20 mA output.

3.1 Input a stable pH (mV) voltage source for the display to indicate the value corresponding to the 4 mA output.

3.2 Set the CONTROL SET POINT control for the current output to be 4 mA.

3.3 Set the OUTPUT CURRENT SELECT switch to the proper position. [LOW-HIGH] for the 20 mA input value to be greater than the 4 mA input value and [HIGH-LOW] for the 20 mA input value to be less than the 4 mA input value.

3.4 Input a stable pH (mV) voltage source for the display to indicate the value corresponding to the 20 mA output. The 20 mA input value must be at least 2 pH (200 mV) away from the 4 mA input value.

3.5 Set the SPAN ADJ control for the current output to be 20 mA.

4. pH mode output

The pH value can be obtained by measuring the output current, “A” based on the following equation. Refer to FIGURE 7A.

$$\text{pH} = \text{pH} (4) + (A-4) \times ((\text{pH} (20) - \text{pH} (4)) / 16)$$

Where: pH (4) is the pH value at 4 mA output

pH (20) is the pH value at 20 mA output

Example: pH (4) = 3, pH (20) = 5

pH = 4 for A = 12 mA

5. mV mode output

The mV value can be obtained by measuring the output current, “A” based on the following equation. Refer to FIGURE 7A.

$$mV = mV(4) + (A-4) \times ((mV(20) - mV(4))/16)$$

Where: mV(4) is the mV value at 4 mA output

MV(20) is the mV value at 20 mA output

Example: mV(4) = 700 mV, mV(20) = 100 mV

$$mV = 400 \text{ mV for } A = 12 \text{ mA}$$

5. mV mode output

The mV value can be obtained by measuring the output current, “A” based on the following equation. Refer to FIGURE 7A.

$$mV = mV(4) + (A-4) \times ((mV(20) - mV(4))/16)$$

Where: mV(4) is the mV value at 4 mA output

MV(20) is the mV value at 20 mA output

Example: mV(4) = 700 mV, mV(20) = 100 mV

$$mV = 400 \text{ mV for } A = 12 \text{ mA}$$

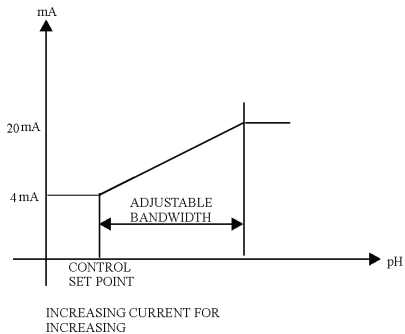
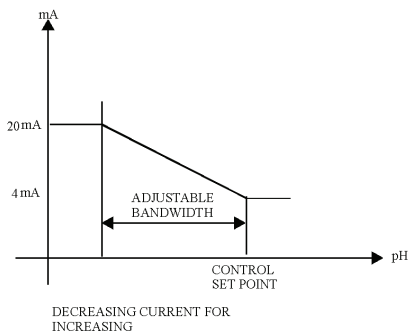

FIGURE 7A

27

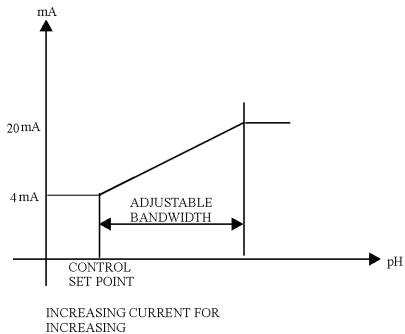
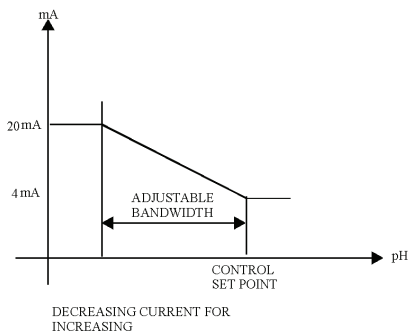

FIGURE 7A

27

CONTROLLER FEATURES OF THE MODEL 3673

The output of the model 3673 consists of two relays and a pulse frequency output. The operation of the 3673 is described below. (Refer to FIGURE 1B, FIGURE 2B)

CONTROLLER INPUT RANGE

pH	0 to 14.00 pH
mV	±1999 mV

PULSE FREQUENCY CONTROL

The pulse frequency output is proportional to the cation/anion concentration of the sample solution. For pH control applications the pulse frequency is proportional to the concentration of the H⁺/OH⁻ ions, instead of the pH values. An antilog circuit is used to convert the measured pH values to ion concentrations, over a proportional bandwidth of two decades.

PROPORTIONAL BANDWIDTH

The proportional bandwidth is factory set to 2 pH (200 mV). The pulse frequency output is the antilog of the pH (mV) value within the proportional band. (Refer to FIGURE 7B)

28

CONTROLLER FEATURES OF THE MODEL 3673

The output of the model 3673 consists of two relays and a pulse frequency output. The operation of the 3673 is described below. (Refer to FIGURE 1B, FIGURE 2B)

CONTROLLER INPUT RANGE

pH	0 to 14.00 pH
mV	±1999 mV

PULSE FREQUENCY CONTROL

The pulse frequency output is proportional to the cation/anion concentration of the sample solution. For pH control applications the pulse frequency is proportional to the concentration of the H⁺/OH⁻ ions, instead of the pH values. An antilog circuit is used to convert the measured pH values to ion concentrations, over a proportional bandwidth of two decades.

PROPORTIONAL BANDWIDTH

The proportional bandwidth is factory set to 2 pH (200 mV). The pulse frequency output is the antilog of the pH (mV) value within the proportional band. (Refer to FIGURE 7B)

28

Example: Proportional band is between pH 3 and pH 5.

1. For increasing pulse rate with increasing input pH values.
The pulse rate at pH 5 is 10 times the pulse rate at pH 4. The pulse rate at pH 4 is 10 times the pulse rate at pH 3.
2. For decreasing pulse rate with increasing input pH values.
The pulse rate at pH 3 is 10 times the pulse rate at pH 4. The pulse rate at pH 4 is 10 times the pulse rate at pH 5.

PULSE RATE ADJUST

The pulse frequency output are relay contacts that can be used to directly drive a pulse pump. The PULSE RATE ADJUST control is used to adjust the output pulse frequency to conform to the specified pulse rate of the pump. It can also be used to control the dosing rate from the pulse pump, since the liquid volume from the pulse pump is directly proportional to the pulse rate.

DEAD BAND ADJUST

In most pH (mV) control systems, the process will settle to some value close to the SET point. The DEAD BAND ADJUST control is used to REST the controller such that the process value is equal to the CONTROL SET POINT value.

Example: Proportional band is between pH 3 and pH 5.

1. For increasing pulse rate with increasing input pH values.
The pulse rate at pH 5 is 10 times the pulse rate at pH 4. The pulse rate at pH 4 is 10 times the pulse rate at pH 3.
2. For decreasing pulse rate with increasing input pH values.
The pulse rate at pH 3 is 10 times the pulse rate at pH 4. The pulse rate at pH 4 is 10 times the pulse rate at pH 5.

PULSE RATE ADJUST

The pulse frequency output are relay contacts that can be used to directly drive a pulse pump. The PULSE RATE ADJUST control is used to adjust the output pulse frequency to conform to the specified pulse rate of the pump. It can also be used to control the dosing rate from the pulse pump, since the liquid volume from the pulse pump is directly proportional to the pulse rate.

DEAD BAND ADJUST

In most pH (mV) control systems, the process will settle to some value close to the SET point. The DEAD BAND ADJUST control is used to REST the controller such that the process value is equal to the CONTROL SET POINT value.

ALARM CONTROL

1. ALARM set point
 - 1.1 Press the ALARM SET POINT switch. The instrument will indicate the alarm set point value. The alarm set point value can be adjusted by the ALARM SET POINT control.
 - 1.2 Release the ALARM SET POINT switch. The instrument will indicate the measured process value.
2. ALARM SET POINT HIGH/LOW SELECT switch
 - 2.1 Set the ALARM SET POINT HIGH/LOW SELECT switch to the high position. The ALARM SET POINT LED will be ON and the ALARM output relay will be energized when the measured value is greater than the alarm set point value. The ALARM SET POINT LED will be OFF and the ALARM output relay will be de-energized when the measured value is less than the alarm set point value.
 - 2.2 Set the ALARM SET POINT HIGH/LOW SELECT switch to the LOW position. The ALARM SET POINT LED will be ON and the ALARM output relay will be energized when the measured value is less than the alarm set point value. The ALARM SET POINT LED will be OFF and the ALARM output relay will be de-energized when the measured value is greater than the alarm set point value.
3. Set point hysteresis

The hysteresis of the model 3673 is factory set to ± 0.1 pH (± 10 mV). For HIGH ALARM settings, the trigger ON point is 0.1 pH (10 mV) above the set point values

30

ALARM CONTROL

1. ALARM set point
 - 1.1 Press the ALARM SET POINT switch. The instrument will indicate the alarm set point value. The alarm set point value can be adjusted by the ALARM SET POINT control.
 - 1.2 Release the ALARM SET POINT switch. The instrument will indicate the measured process value.
2. ALARM SET POINT HIGH/LOW SELECT switch
 - 2.1 Set the ALARM SET POINT HIGH/LOW SELECT switch to the high position. The ALARM SET POINT LED will be ON and the ALARM output relay will be energized when the measured value is greater than the alarm set point value. The ALARM SET POINT LED will be OFF and the ALARM output relay will be de-energized when the measured value is less than the alarm set point value.
 - 2.2 Set the ALARM SET POINT HIGH/LOW SELECT switch to the LOW position. The ALARM SET POINT LED will be ON and the ALARM output relay will be energized when the measured value is less than the alarm set point value. The ALARM SET POINT LED will be OFF and the ALARM output relay will be de-energized when the measured value is greater than the alarm set point value.
3. Set point hysteresis

The hysteresis of the model 3673 is factory set to ± 0.1 pH (± 10 mV). For HIGH ALARM settings, the trigger ON point is 0.1 pH (10 mV) above the set point values

30

and the trigger OFF point is 0.1 pH (10 mV) below the set point values. For LOW ALARM settings, the trigger ON point is 0.1 pH (10 mV) below the set point values and the trigger OFF point is 0.1 pH (10 mV) above the set point values.

PULSE FREQUENCY OUTPUT

1. CONTROL set point
 - 1.1 Press the CONTROL SET POINT switch. The instrument will indicate the set point value. The control set point value can be adjusted by the CONTROL SET POINT control.
 - 1.2 Release the CONTROL SET POINT switch. The instrument will indicate the measured process value.
2. PULSE FREQUENCY SELECT switch
 - 2.1 Set the PULSE FREQUENCY SELECT switch to the [LOW-HIGH] position.
 - 2.1.1 The CONTROL SET POINT LED will be ON and the CONTROL output relay will be energized when the measured value is greater than the set point value. The CONTROL SET POINT LED will be OFF and the CONTROL output relay will be de-energized when the measured value is less than the set point value.
 - 2.1.2 The pulse frequency output is close to 0 pulse per minute, ppm, at the CONTROL SET POINT value. The pulse frequency output will increase for increasing input pH (mV) values. (Refer to FIGURE 7B)

and the trigger OFF point is 0.1 pH (10 mV) below the set point values. For LOW ALARM settings, the trigger ON point is 0.1 pH (10 mV) below the set point values and the trigger OFF point is 0.1 pH (10 mV) above the set point values.

PULSE FREQUENCY OUTPUT

1. CONTROL set point
 - 1.1 Press the CONTROL SET POINT switch. The instrument will indicate the set point value. The control set point value can be adjusted by the CONTROL SET POINT control.
 - 1.2 Release the CONTROL SET POINT switch. The instrument will indicate the measured process value.
2. PULSE FREQUENCY SELECT switch
 - 2.1 Set the PULSE FREQUENCY SELECT switch to the [LOW-HIGH] position.
 - 2.1.1 The CONTROL SET POINT LED will be ON and the CONTROL output relay will be energized when the measured value is greater than the set point value. The CONTROL SET POINT LED will be OFF and the CONTROL output relay will be de-energized when the measured value is less than the set point value.
 - 2.1.2 The pulse frequency output is close to 0 pulse per minute, ppm, at the CONTROL SET POINT value. The pulse frequency output will increase for increasing input pH (mV) values. (Refer to FIGURE 7B)

- 2.2 Set the PULSE FREQUENCY SELECT switch to the [HIGH-LOW] position.
- 2.2.1 The CONTROL SET POINT LED will be ON and the CONTROL output relay will be energized when the measured value is less than the set point value. The CONTROL SET POINT LED will be OFF and the CONTROL output relay will be de-energized when the measured value is greater than the set point value.
- 2.2.2 The pulse frequency output is close to 0 pulse per minute, ppm, at the CONTROL SET POINT value. The pulse frequency output will decrease for increasing input pH (mV) values. (Refer to FIGURE 7B)

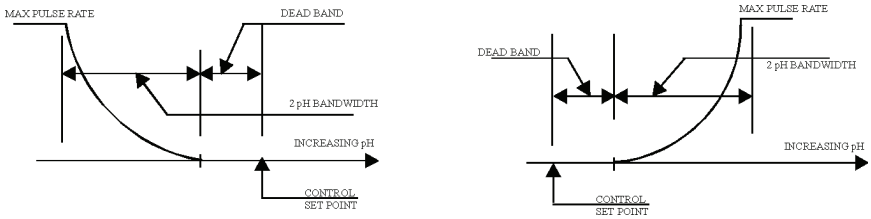

FIGURE 7B

32

- 2.2 Set the PULSE FREQUENCY SELECT switch to the [HIGH-LOW] position.
- 2.2.1 The CONTROL SET POINT LED will be ON and the CONTROL output relay will be energized when the measured value is less than the set point value. The CONTROL SET POINT LED will be OFF and the CONTROL output relay will be de-energized when the measured value is greater than the set point value.
- 2.2.2 The pulse frequency output is close to 0 pulse per minute, ppm, at the CONTROL SET POINT value. The pulse frequency output will decrease for increasing input pH (mV) values. (Refer to FIGURE 7B)

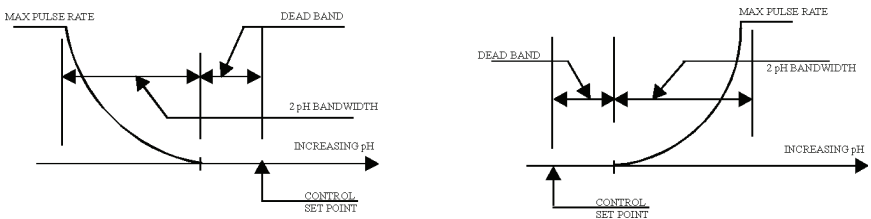

FIGURE 7B

32

CONTROLLER OUTPUT FEATURES OF THE MODELS 3675 AND 3676

The output of the modes 3675 and 3676 consists of two alarm relays and an isolated 4-20 mA output. The operation of the 3675 and 3676 is described below. (Refer to FIGURE 1C,1D, FIGURE 2C,2D)

CONTROLLER INPUT RANGE

1. Relay outputs
 - pH 0 to 14.00 pH
 - mV ±1999 mV
2. Current output
 - pH 0 to 14.00 pH
 - mV 0 to 14.00 mV

ALARM RELAY AND LED FORMATS

1. HIGH ALARM set point
 - 1.1 Press the HIGH ALARM SET POINT switch. The instrument will indicate the alarm set point value. The alarm set point value can be adjusted by the HIGH ALARM SET POINT control.

33

CONTROLLER OUTPUT FEATURES OF THE MODELS 3675 AND 3676

The output of the modes 3675 and 3676 consists of two alarm relays and an isolated 4-20 mA output. The operation of the 3675 and 3676 is described below. (Refer to FIGURE 1C,1D, FIGURE 2C,2D)

CONTROLLER INPUT RANGE

1. Relay outputs
 - pH 0 to 14.00 pH
 - mV ±1999 mV
2. Current output
 - pH 0 to 14.00 pH
 - mV 0 to 14.00 mV

ALARM RELAY AND LED FORMATS

1. HIGH ALARM set point
 - 1.1 Press the HIGH ALARM SET POINT switch. The instrument will indicate the alarm set point value. The alarm set point value can be adjusted by the HIGH ALARM SET POINT control.

33

- 1.2 Release the HIGH ALARM SET POINT switch. The instrument will indicate the measured process value.
- 1.3 The HIGH ALARM SET POINT LED will be ON and the HIGH ALARM output relay will be energized when the measured value is greater than the alarm set point value. The HIGH ALARM SET POINT LED will be OFF and the HIGH ALARM output relay will be de-energized when the measured value is less than the alarm set point value.
2. LOW ALARM set point
 - 2.1 Press the LOW ALARM SET POINT switch. The instrument will indicate the alarm set point value. The alarm set point value can be adjusted by the LOW ALARM SET POINT control.
 - 2.2 Release the LOW ALARM SET POINT switch. The instrument will indicate the measured process value.
 - 2.3 The LOW ALARM SET POINT LED will be ON and the LOW ALARM output relay will be energized when the measured value is less than the alarm set point value. The LOW ALARM SET POINT LED will be OFF and the LOW ALARM output relay will be de-energized when the measured value is greater than the alarm set point value.
3. Set point hysteresis

The hysteresis of the models 3675 and 3676 is factory set to ± 0.1 pH (± 10 mV). For HIGH ALARM set points, the trigger ON point is 0.1 pH (10 mV) above the set point values and the trigger OFF point is 0.1 pH (10 mV) below the set point values. For

34

- 1.2 Release the HIGH ALARM SET POINT switch. The instrument will indicate the measured process value.
- 1.3 The HIGH ALARM SET POINT LED will be ON and the HIGH ALARM output relay will be energized when the measured value is greater than the alarm set point value. The HIGH ALARM SET POINT LED will be OFF and the HIGH ALARM output relay will be de-energized when the measured value is less than the alarm set point value.
2. LOW ALARM set point
 - 2.1 Press the LOW ALARM SET POINT switch. The instrument will indicate the alarm set point value. The alarm set point value can be adjusted by the LOW ALARM SET POINT control.
 - 2.2 Release the LOW ALARM SET POINT switch. The instrument will indicate the measured process value.
 - 2.3 The LOW ALARM SET POINT LED will be ON and the LOW ALARM output relay will be energized when the measured value is less than the alarm set point value. The LOW ALARM SET POINT LED will be OFF and the LOW ALARM output relay will be de-energized when the measured value is greater than the alarm set point value.
3. Set point hysteresis

The hysteresis of the models 3675 and 3676 is factory set to ± 0.1 pH (± 10 mV). For HIGH ALARM set points, the trigger ON point is 0.1 pH (10 mV) above the set point values and the trigger OFF point is 0.1 pH (10 mV) below the set point values. For

34

LOW ALARM set points, the trigger ON point is 0.1 pH (10 mV) below the set point values and the trigger OFF point is 0.1 pH (10 mV) above the set point values.

ISOLATED 4-20 mA OUTPUT

1. pH mode output

The 4-20 mA output is 4 mA at 0 pH and 20 mA at 14 pH. The pH value can be obtained by measuring the output current, “A” based on the following equation. (Refer to FIGURE 7C)

$$\text{pH} = (A-4) \times (14/16)$$

Example: A = 12 mA for pH = 7.00

2. mV mode output

The 4-20 mA output is 4 mA at 0 mV and 20 mA at 1400 mV. The mV value can be obtained by measuring the output current, “A” based on the following equation. (Refer to FIGURE 7C)

$$\text{mV} = (A-4) \times (1400/16)$$

Example: A = 12 mA for mV = 700

35

LOW ALARM set points, the trigger ON point is 0.1 pH (10 mV) below the set point values and the trigger OFF point is 0.1 pH (10 mV) above the set point values.

ISOLATED 4-20 mA OUTPUT

1. pH mode output

The 4-20 mA output is 4 mA at 0 pH and 20 mA at 14 pH. The pH value can be obtained by measuring the output current, “A” based on the following equation. (Refer to FIGURE 7C)

$$\text{pH} = (A-4) \times (14/16)$$

Example: A = 12 mA for pH = 7.00

2. mV mode output

The 4-20 mA output is 4 mA at 0 mV and 20 mA at 1400 mV. The mV value can be obtained by measuring the output current, “A” based on the following equation. (Refer to FIGURE 7C)

$$\text{mV} = (A-4) \times (1400/16)$$

Example: A = 12 mA for mV = 700

35

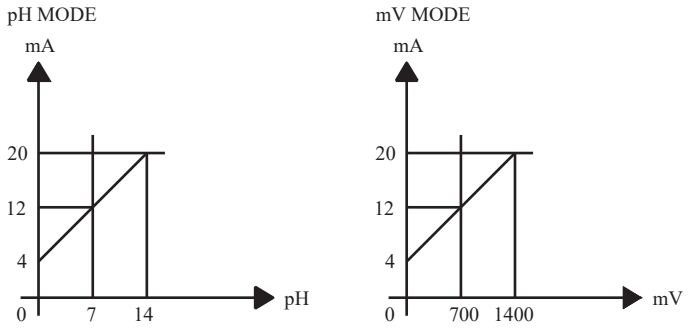

FIGURE 7C

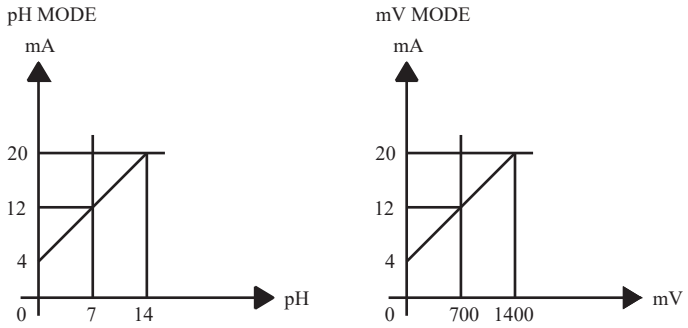

FIGURE 7C

WARRANTY

Pulse Instruments warrants this product to be free from significant deviations in material and workmanship for a period of 1 year from date of purchase. If repair or adjustment is necessary and has not been the result of abuse or misuse, within the year period, please return-freight-prepaid and the correction of the defect will be made without charge. If you purchased the item from our Pulse Instruments and it is under warranty, please contact them to notify us of the situation. Our Service Department alone will determine if the product problem is due to deviations or customer misuse.

Out-of-warranty products will be repaired on a charge basis.

RETURN OF ITEMS

Authorization must be obtained from one of our representatives before returning items for any reason. When applying for authorization, please have the model and serial number handy, including data regarding the reason for return. For your protection, items must be carefully packed to prevent damage in shipment and insured against possible damage or loss. PI will not be responsible for damage resulting from careless or insufficient packing. A fee will be charged on all unauthorized returns.

WARRANTY

Pulse Instruments warrants this product to be free from significant deviations in material and workmanship for a period of 1 year from date of purchase. If repair or adjustment is necessary and has not been the result of abuse or misuse, within the year period, please return-freight-prepaid and the correction of the defect will be made without charge. If you purchased the item from our Pulse Instruments and it is under warranty, please contact them to notify us of the situation. Our Service Department alone will determine if the product problem is due to deviations or customer misuse.

Out-of-warranty products will be repaired on a charge basis.

RETURN OF ITEMS

Authorization must be obtained from one of our representatives before returning items for any reason. When applying for authorization, please have the model and serial number handy, including data regarding the reason for return. For your protection, items must be carefully packed to prevent damage in shipment and insured against possible damage or loss. PI will not be responsible for damage resulting from careless or insufficient packing. A fee will be charged on all unauthorized returns.

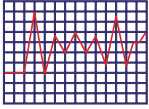

PULSE INSTRUMENTS

3233 Mission Oaks Blvd., Unit P - Camarillo, CA 93012 - (800) 462-1926 - support@pulseinstrument.com

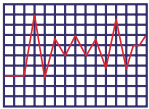

PULSE INSTRUMENTS

3233 Mission Oaks Blvd., Unit P - Camarillo, CA 93012 - (800) 462-1926 - support@pulseinstrument.com